

Part number **EC12D1524403** 12mm Size Insulated Shaft Type EC12D Series

Standard ?

Basic information



+ ZOOM

Actuator length	17.5mm
Detent torque	5±3mN·m
Number of detent	30
Number of pulse	15
Control part orientation	Vertical
Operating force of switch	3N
Travel of push-on switch	0.5mm
Dimensions	12mm size

Specifications

Operating temperature range		-40°C to +85°C
Electrical performance	Ratings	1mA 5V DC
	Output signal	Two phase A and B
	Max./min. operating current (Resistive load)	10mA/1mA
	Insulation resistance	100MΩ min. 250V DC
Voltage proof		300V AC for 1 minute or 360V AC for 1s
Mechanical performance	Detent torque	5±3mN·m
	Push-pull strength	100N
Durability	Operating life	30,000 cycles
Push-on switch specifications	Contact arrangement	Single pole single throw (Push-on)
	Travel	0.5±0.3mm
	Operating force	3(+1.5, -1)N
	Ratings	1mA 5V DC (10mA 5V DC max. ratings)
	Contact resistance (Initial performance/After lifetime)	100mΩ max./200mΩ max.
Operating life		30,000 times
Minimum order unit(pcs.)	Japan	1,280
	Export	2,560

Dimensions

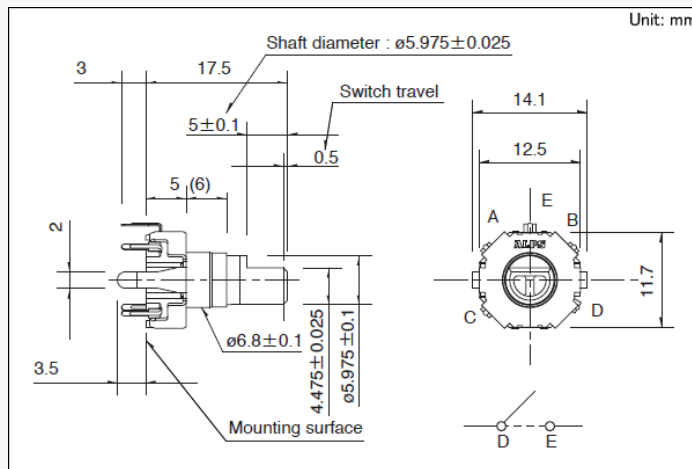

[Open an expandable image in a separate window](#)

Mounting Hole Dimensions

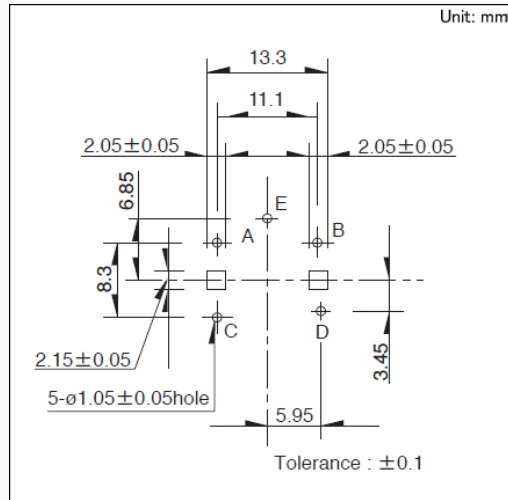

[Open an expandable image in a separate window](#)

Viewed from mounting face.

Output Wave

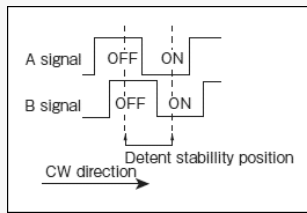

[Open an expandable image in a separate window](#)

Sliding Noise

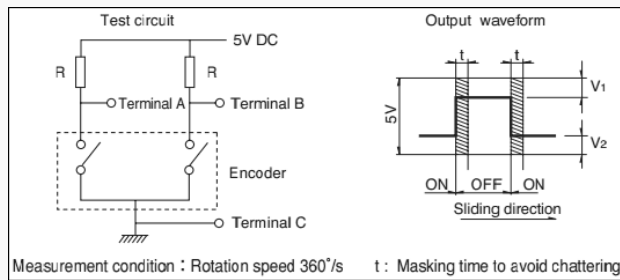

[Open an expandable image in a separate window](#)

V1=V2=1.5V max.
At R=10kΩ Chattering: 3ms max. Bounce: 2ms max.

Packing Specifications

Tray

Number of packages (pcs.)

1 case / Japan 1,280

1 case / export packing 2,560

Export package measurements (mm)

540×360×290

Soldering Conditions

Reference for Dip Soldering

Preheating

Soldering surface temperature 100°C max.

Heating time 1 min. max.

Dip soldering

Soldering temperature 260±5°C

Soldering time 3±1s

No. of solders

2 time max.

Reference for Hand Soldering

Tip temperature

350°C max.

Soldering time

3s max.

No. of solders

1 time

Notes are common to this series/models

1. This site catalog shows only outline specifications. When using the products, please obtain formal specifications for supply.
2. Please place purchase orders per minimum order unit (integer).
3. Products other than those listed in the above chart are also available. Please contact us for details.
4. Nuts and washers are not included. If required, please contact us.
5. This products can be used in vehicles. (EC12D only)
Although these products are designed to perform over a wide operating temperature range, please ensure that you receive and read the formal delivery specifications before use.

Cautions

Pulse count process

With respect to pulse count design of encoders, operational speed, sampling time, and masking time, etc. should be taken into consideration. Be sure to confirm these factors before using the encoder. For your pulse count design, consider adding C/R filters on your circuit as shown below.

Example of filter circuit

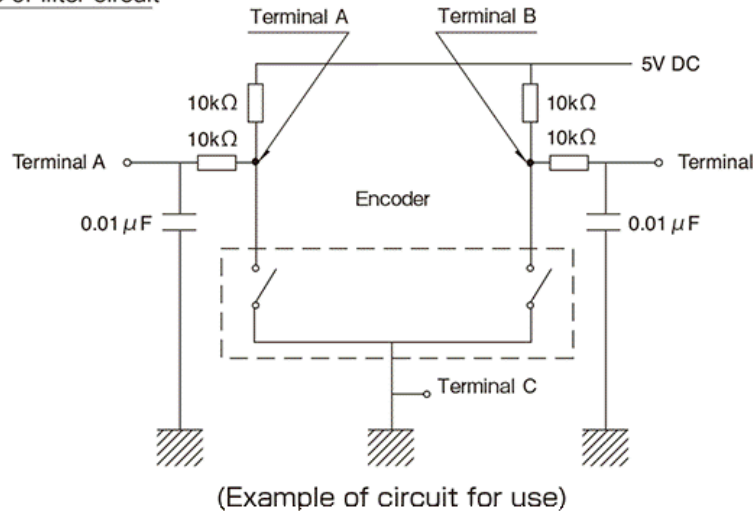

Output Specifications

Depending on the product, output at encoder detent positions can be specified either for both signals A and B, or for signal A only. Specifications vary according to the number of detents and other factors.

Example where both signal A and B output can be specified

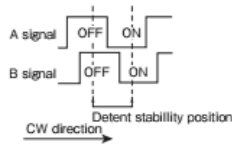

Example where only signal A output can be specified

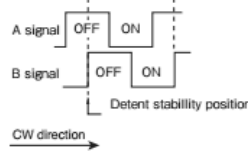

※On / off status of signal B at detent stability point is not specified

Dew Condensation

Do not use this product where dew or water drops might occur on the pattern surface of the encoder, etc. Insulation deterioration or shorting may occur.

Usage Environment

Use of the encoders in a dusty environment may lead the dusts entering through the openings and cause imperfect contact or malfunction. Take this into account for set design. Corrosive gas if generated by peripheral parts of a set, malfunction such as imperfect contact may occur. Thorough investigation shall be required before hand.

Operation

The encoders will be break if you apply a greater stress than that specified. Take great care not to let the encoders be subject to greater stress than specified.

Looseness of the Shaft

When long shafts are being employed, the looseness (deviation) tends to grow in proportion to the shaft length. Checking shaft looseness under actual operational conditions is recommended.

Installation

Insert these encoders to the specified mounting surface and mount them horizontally. If not mounted horizontally, these encoders will malfunction. Tighten the mounting screws by applying the specified torque. Tightening with larger torque than the specified one will result in malfunction or breakage of screws. Protect small and thin encoders from external forces in the set mounting process.

Soldering

1. Do not employ wiring designs and soldering methods as illustrated in the schematic drawing. Molten solder flowing over the upper surface of PC board can cause imperfect contacts. Solder all metal lugs into a substrate before use.

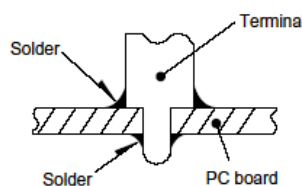

2. Applying load to terminals during soldering under certain conditions may cause deformation and electrical property degradation.
3. Avoid use of water-soluble soldering flux, since it may corrode the switches.
4. Check and conform to soldering requirements under actual mass production conditions.

5. When soldering twice, wait until the first soldered portion cools to normal temperature. Continuous heating will deform the external portions, loosen or dislodge terminals, or may deteriorate their electrical characteristics.
6. Flux from around and above the PC board should not adhere to the switches.
7. After mounting the switches, if you intend to put the board into an oven in order to harden adhesive for other parts, please consult with Alps Alpine.
8. If you use a through-hole PC board or a PC board thinner or thicker than the recommendation, there may be greater heat stress. Verify the soldering conditions thoroughly before use.
9. Solder the switches with detent at the detent position. Soldering switches fixed at the center of the detent may deform the detent mechanisms.
10. No washing.

Use of Chemicals

Since synthetic resins such as polycarbonate are being used as the material for the insulated type shafts, avoid using this product under gassy environments containing such chemicals as ammonia, amines, alkaline water solutions, aromatic hydrocarbons, ketones, esters and halogenated hydrocarbons, especially under intensive gas environments.

Operation at Low Temperature

When these products are expected to be used under low temperature environments such as applications for car radios and car stereos, we can customize them for easier and more smooth rotary movements. When placing orders, indicate whether the low temperature specification is necessary or not.

Storage

1. Store the products as delivered, at a normal temperature and humidity, without direct sunshine and corrosive gas ambient. Use them at an earliest possible timing, not later than six months upon receipt.
2. After breaking the seal, keep the products in a plastic bag to shut out ambient air, store them in the same environment as above, and use them up as soon as possible.
3. Do not stack too many switches.

Measurement and Test Methods

Rotational Torque (Operating Force)

Measures the torque (operating force) necessary to rotate (move) the shaft (lever). Unless otherwise specified, measurement shall be made at ambient temperatures of 5 to 35°C, the shaft rotational speed shall be 60° per second, and the lever traveling speed shall be 20mm per second.

Shaft Wobble

Measures the amount of deflection at the specified position from the reference plane, with the specified bending moment, applied perpendicularly to the shaft from directions 180 degrees with respect to each other.

Withstand Voltage

Applies AC voltage to the specified spot for a minute and then checks for arc, burning, dielectric breakdown and other abnormalities. Respective terminals may be tested as a group. The sections described below shall be tested unless otherwise specified. However, if the section concerned is so constructed as to conduct, that particular part shall not be tested.

Insulation Resistance

Applies specified voltage to the specified locations and then measures the insulation resistance with a megger. The locations described below shall be tested unless otherwise specified. However, if the section concerned is so constructed as to conduct, that particular part shall not be tested.

Sections to be Tested for Withstand Voltage and Insulation Resistance

- Between terminal and shaft (lever).
- Between terminal and metal cover (frame).

Shaft (Lever) Strength against Push/Pull Actions

Applies a specified force in the axial direction of the shaft (lever) for 19 seconds and then checks the operating part and other sections for deformation, breakage, operating conditions, etc.